

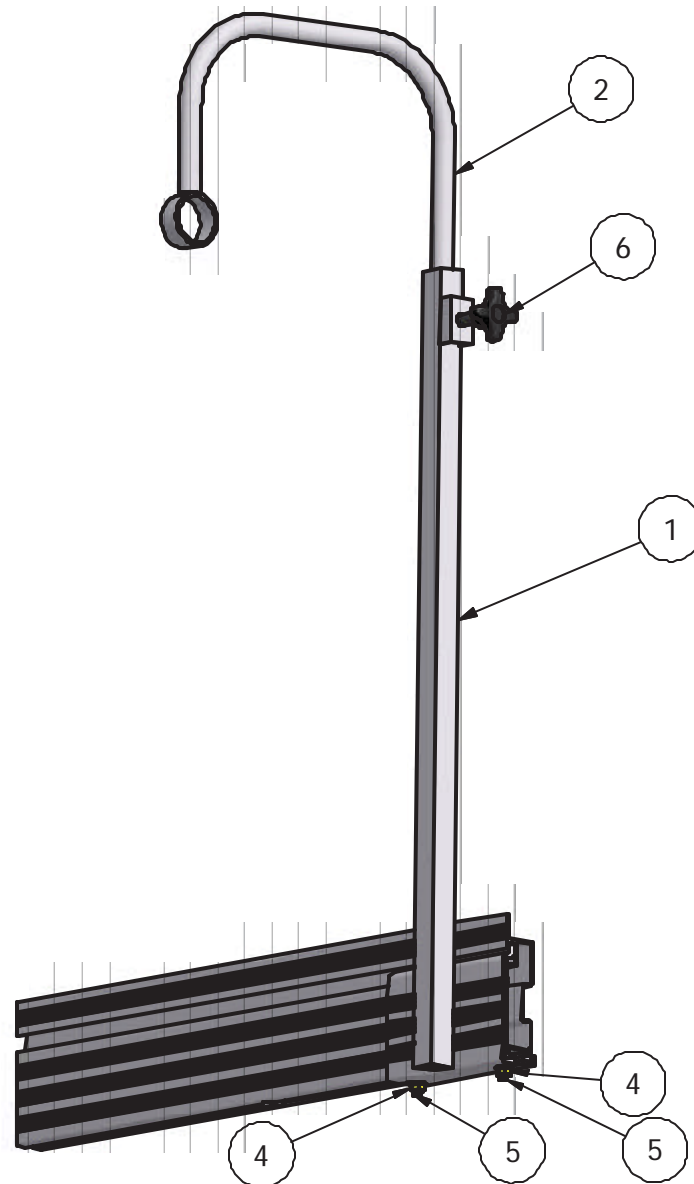

Plant Hanger



PARTS LIST			
ITEM	QTY	PART NUMBER	DESCRIPTION
1	1	VM-114-03	BASE XMNT
2	1	VM-114-05	HOOK XMNT
3	1	HD-00058	1/2 SQ_NUT BRASS
4	2	HD-00056	3/8 BRASS FLANGE NUT
5	2	HD-00059	3/8 X 1 CAR (SS)
6	1	HD-00159	5 PRONG KNOB

5

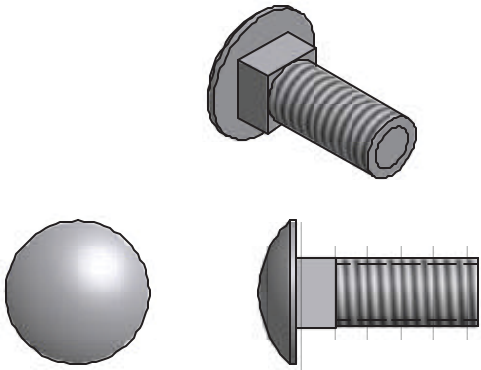

3/8 X 1 S.S. CARRIDGE BOLT (2 REQ'D)

4

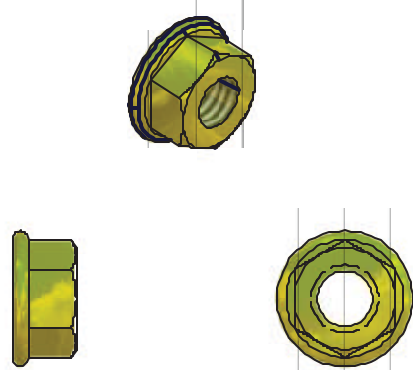

3/8 FLANGE NUT BRASS (2 REQ'D)

3

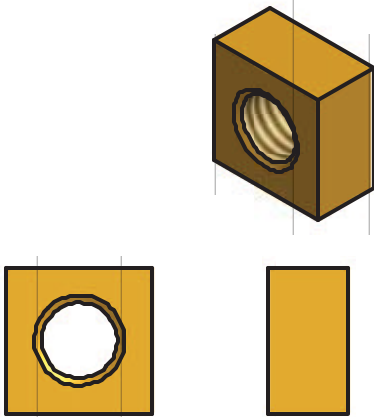

1/2" SQ NUT BRASS (1 REQ'D)

6

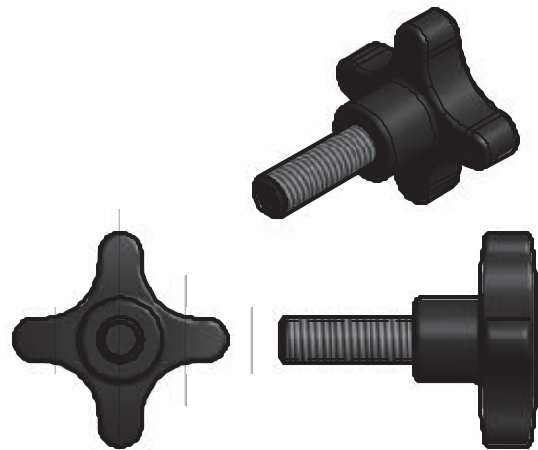

5 PRONG KNOB (1 REQ'D)

2

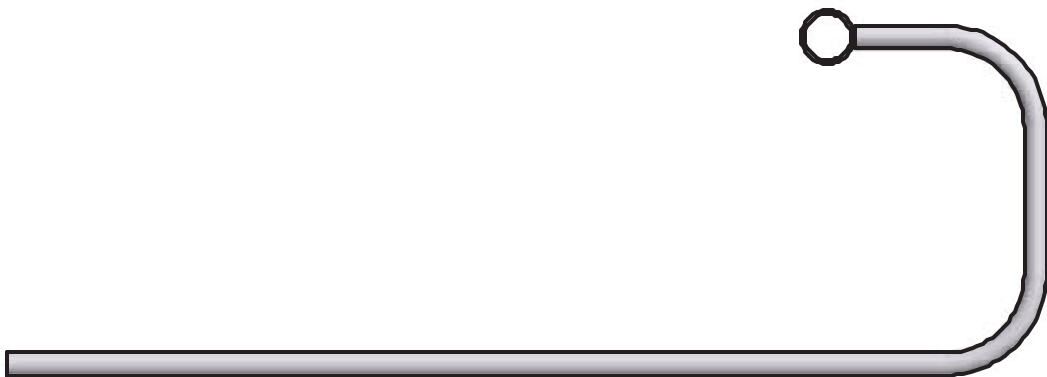

HOOK XMNT (1 REQ'D)

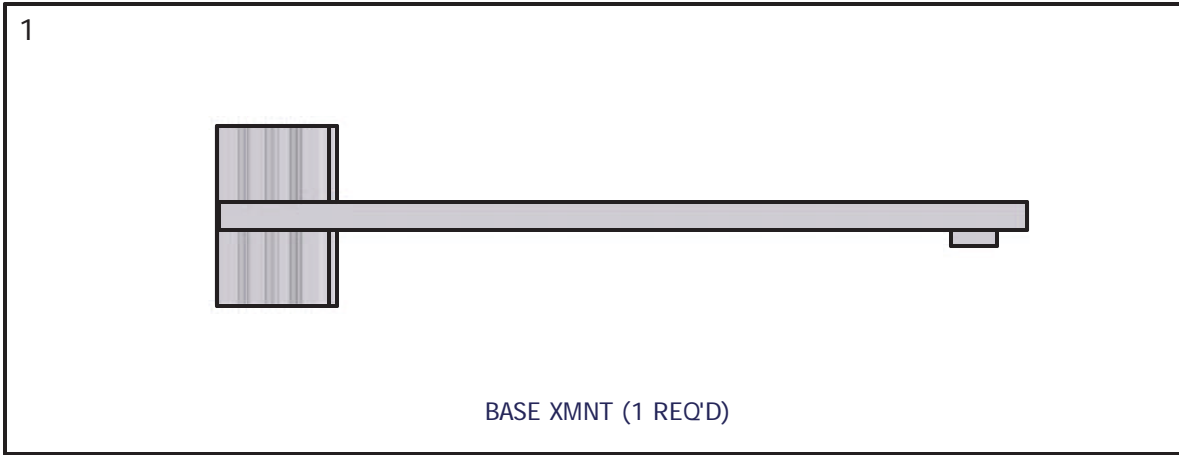

To insure your safety while assembling your Voyager product:

- Fully read and understand the assembly instructions
- Do not assemble this product if items are missing or damaged
- Wear protective gloves, clothing and eye wear when assembling this product

Installation procedure

The following tool will be needed: 9/16" wrench

1. Insert head of carriage bolts into raceway on the underside of the rail and slide to desired location on dock. **Per diagram A**
2. Slide bracket into dock rail and put carriage bolts into bracket and attach flange nuts. **Per diagram B.**
3. Take 9/16" wrench and tighten flange nut.
4. Put square nut into channel, thread 5 prong knob through nut and start into upright post.
5. Slide upper tube into upright post, set to desired location and tighten 5 prong knob. **Per diagram C.**

